

Installation instructions : Sirius Connect LED Recti-light SY9570

Thank you for purchasing this SycamoreLED.com product. Please make sure instructions are followed carefully prior to and during installation and product is not altered, otherwise warranty may not be valid. For technical support or warranty information please visit www.sycamoreLED.com, or call our dedicated technical helpline +44 (0) 113 2866686.

IMPORTANT—Please read prior to installation

- 1) Please read these instructions carefully before commencing any work
- 2) Please retain these instructions for future reference
- 3) It is strongly recommended that this unit is installed by a qualified electrician in accordance with the IEE wiring regulations and building regulations
- 4) To prevent electrocution switch the power off at the mains supply before installing or maintaining this fitting
- 5) Ensure others cannot restore the electrical supply without your knowledge
- 6) The PSU must be rated 12VDC and be compatible with the pre-wired connector system of this product
- 7) Never exceed the wattage stated

DIAGRAMS

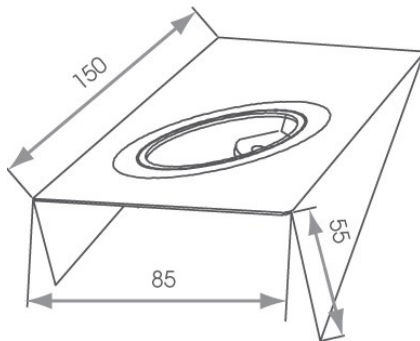

INSTALLATION

- 1) Fix rectangular body in position using screws provided
- 2) Ensure that cable is located via cut out on spacer
- 3) Connect into PSU using fast fit connector
- 4) Insert light into spacer and check operation

CARE IN USE

- 1) Please note this fitting has non replaceable parts
- 2) Always switch off or disconnect from the mains when cleaning the product.
- 3) We recommend cleaning with a soft dry cloth. Do not use scourers, abrasives or chemical cleaners.

sycamore SY9570



This luminaire contains built-in LED lamps.

A⁺⁺

A⁺

A

~~B~~

~~C~~

~~D~~

~~E~~

} LED

The lamps cannot be changed in the luminaire.

874/2012

